

DATE	SYM	REVISION	AUTH	CHK
2/28/02	A	REV. INLET	BLO	JF
4/8/02	B	REV. OUTLET & POCKETS	BLO	JF
1/28/03	C	ADDED ANCHOR LUG DETAILS	GT	JF
8/29/05	D	ADD DIM., ELEVATION TABLE	KF	JF
9/19/06	E	MOD. MAKE-UP, ANCHOR BOLTS	KF	JBH
4/14/09	F	REVISED HEIGHT	KF	JBH
5/25/10	G	REV. MAKE-UP, LOUVER MATERIAL	KF	JBH
10/26/11	H	REV. MAKE-UP FLOAT	LM	JBH
5/6/13	I	REV. ANCHOR LUG & POCKETS	FP	JBH
8/7/14	J	UPDATED DRAWING	FP	JBH
10/9/14	K	I-BEAM POCKET DIMENSION	FP	JBH

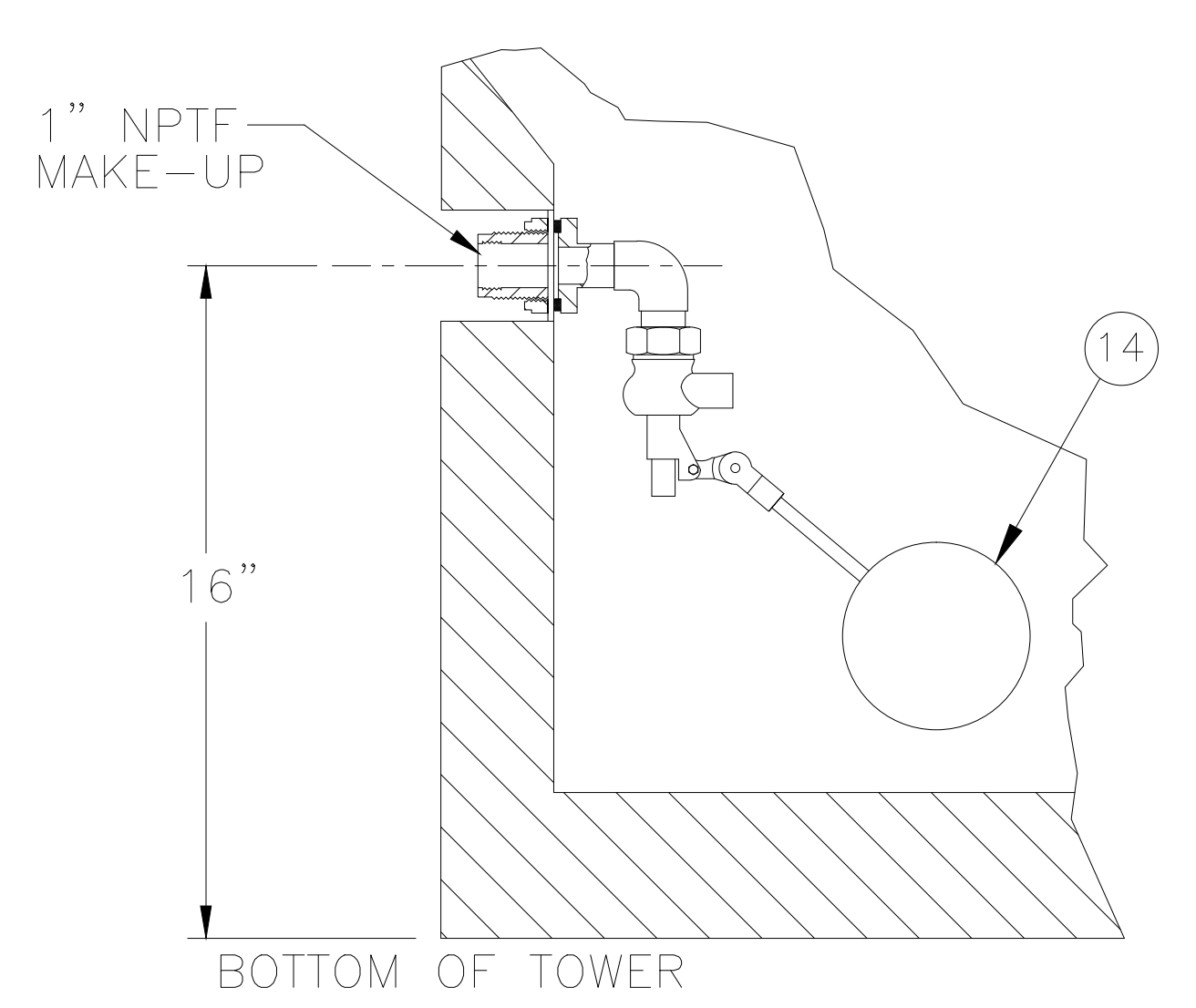

DETAIL A
MAKE-UP
NTS

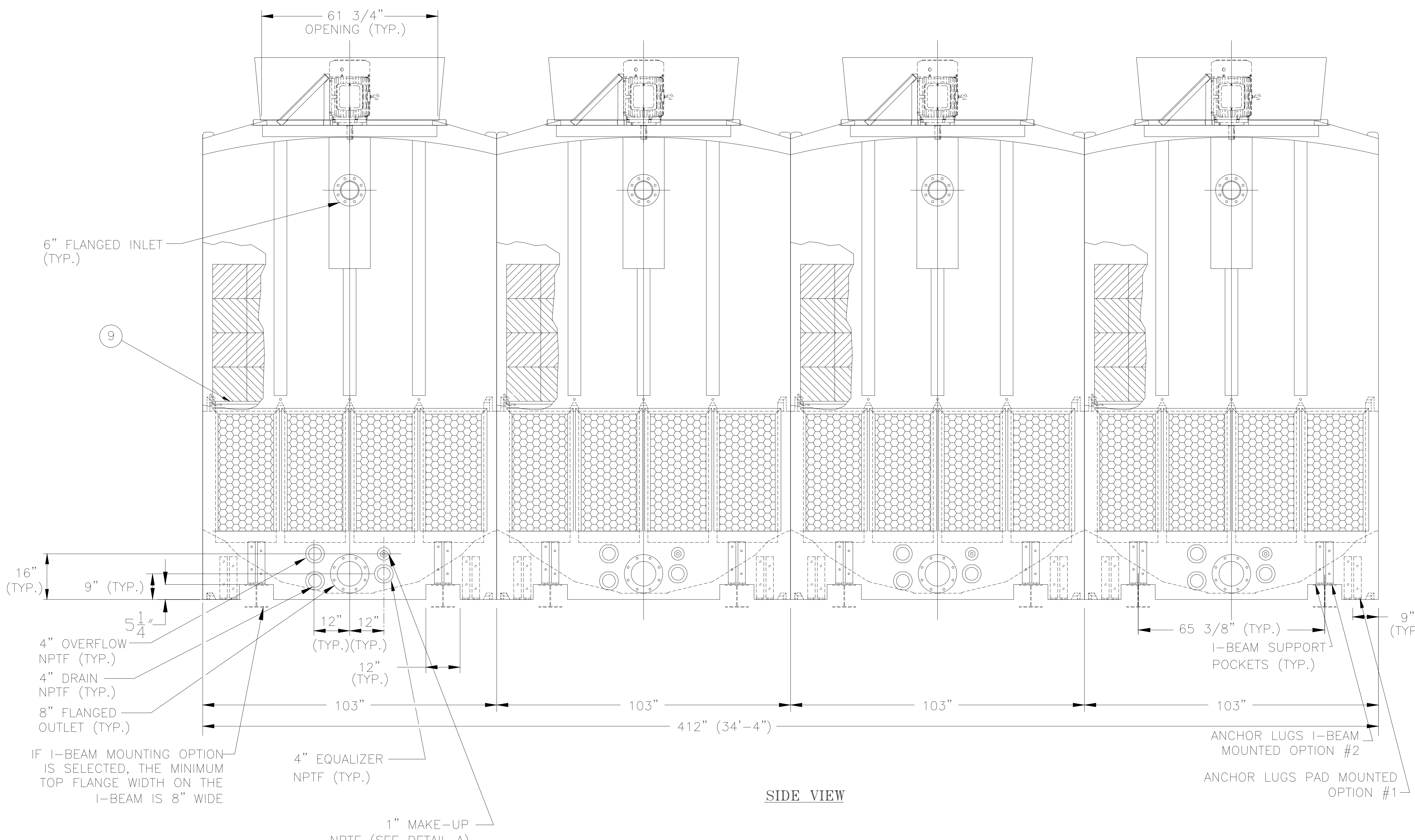
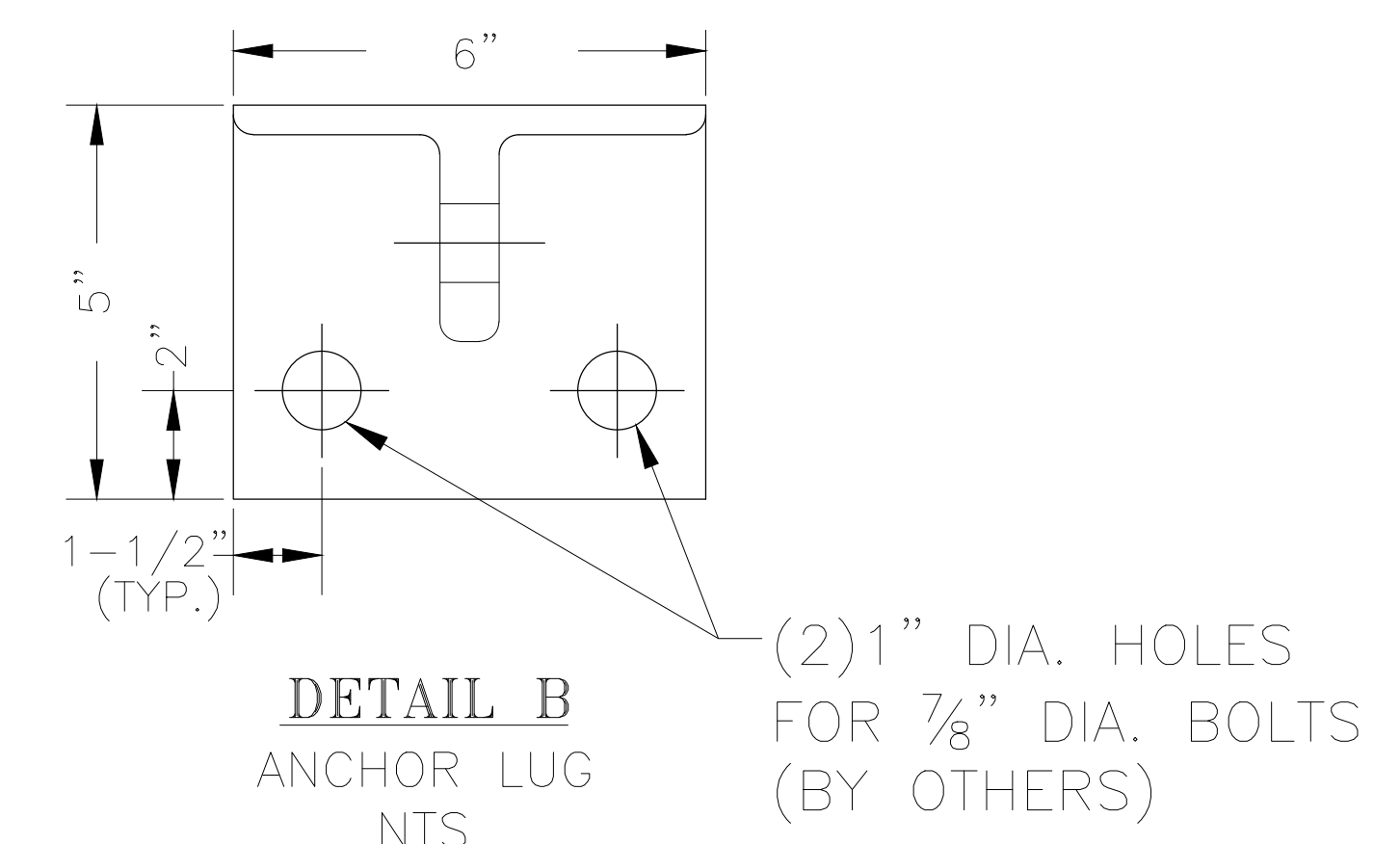

DETAIL B
ANCHOR LUG
NTS
(2) 1" DIA. HOLES
FOR 7/8" DIA. BOLTS
(BY OTHERS)

SIDE VIEW

NOTES:

- SEE DRAWING DT-D-87-905-1 FOR PLAN VIEW & ELEVATION.

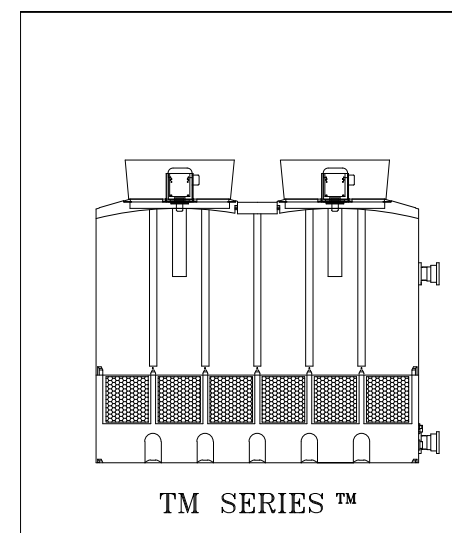

DELTA COOLING TOWERS, INC.
185 US HIGHWAY 206, ROXBURY TWP. NJ, 07836
PH 973.586.2201 FAX 973.586.2243

TITLE **4 CELL**

TM SERIES™ DWN BY *Bonnie L. Oddo*
APPVD BY *John Flaherty*

SCALE 5/8"=1'-0" DWG NO. **DT-D-87-905-2**
DATE 6/14/01