

TOTAL HP	SEE MODEL
DRY WT.	6,500 LBS.
OPER. WT. SUMP FULL	12,200 LBS.
OPERATING WT. BOTTOM OUTLET	8,450 LBS.
SUMP CAP	480 GALLONS

MODEL SERIES	DIM "A"
TM1XX3XX	68"
TM1XX4XX	77 1/2"

IF I-BEAM MOUNTING OPTION IS SELECTED, THE MINIMUM TOP FLANGE WIDTH ON THE I-BEAM IS 8" WIDE

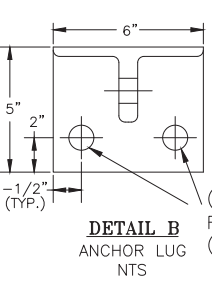
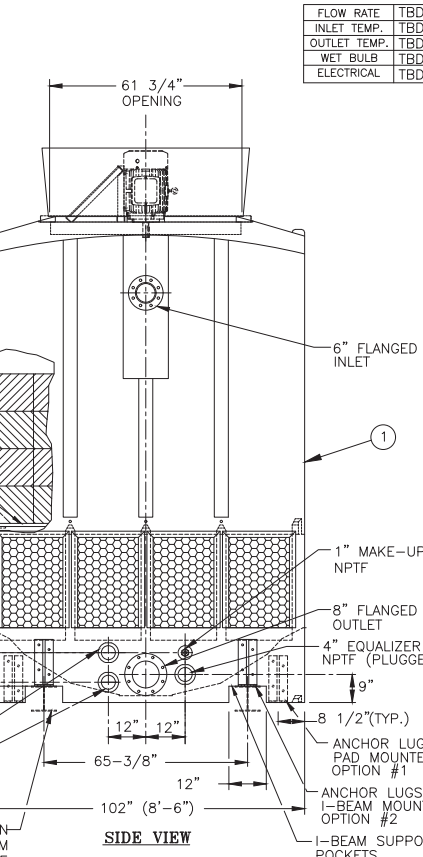
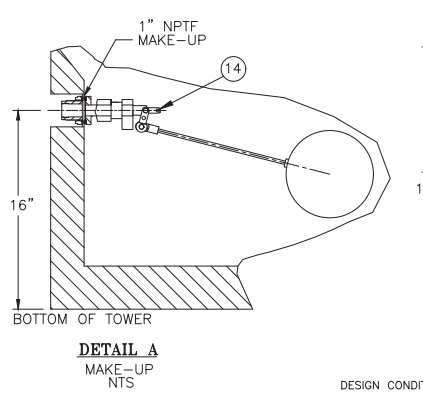

(2) 1" DIA. HOLES FOR 7/8" DIA. BOLTS (BY OTHERS)

NOTES:

- DIMENSIONS SHOWN ARE NOMINAL AND ARE SUBJECT TO FABRICATION TOLERANCES.
- EXTERNAL PIPING MUST BE INDEPENDENTLY SUPPORTED.
- PIPING AND BULKHEAD FITTING MATERIAL IS PVC.
- HARDWARE MATERIAL IS TYPE 304 STAINLESS STEEL.
- FAN ASSEMBLY SHIPPED INSTALLED ON TOWER.
- MAXIMUM INLET WATER TEMPERATURE 140°F. (CONSULT FACTORY FOR HIGHER TEMP. APPLICATIONS.)
- ALL DIMENSIONS ARE IN INCHES.
- ALL WEIGHTS ARE IN POUNDS. DRY WT. INCLUDES; FAN ASSEMBLY AND TOWER COMPLETE. OPERATING WT. INCLUDES A FULL SUMP.
- TOWER MOUNTING OPTION #1 - CONCRETE PAD - ENTIRE TOWER BASIN BOTTOM SURFACE TO BE FULLY SUPPORTED BY AN APPROPRIATELY SIZED CONCRETE PAD.
- TOWER MOUNTING OPTION #2 - BEAM SUPPORTED VIA I-BEAM POCKETS. \*SUPPORT BEAMS AND ANCHOR BOLTS ARE TO BE FURNISHED BY OTHERS. \*BEAMS SHOULD HAVE A MINIMUM TOP FLANGE WIDTH OF 8"(8"x31# RECOMMENDED) AND BE IN ACCORDANCE WITH ACCEPTABLE STRUCTURAL DESIGN PRACTICES. THESE BEAMS SHOULD BE LOCATED IN THE INTEGRALLY MOLDED I-BEAM POCKETS, AND SHOULD OVER-RUN THE LENGTH OF THE UNIT. \*DO NOT WELD OR BOLT DOWN BEAMS PRIOR TO SETTING THE COOLING TOWER SUMP(S).
- FINAL YARD PIPING TO AND FROM THE TOWER SHOULD BE FABRICATED FOLLOWING INSTALLATION OF THE TOWERS ONSITE. DUE TO MANUFACTURING AND INSTALLATION TOLERANCES, PREFABRICATION OF EXTERNAL PIPING IS NOT RECOMMENDED.

DESIGN CONDITIONS

FLOW RATE	TBD GPM
INLET TEMP.	TBD°F
OUTLET TEMP.	TBD°F
WET BULB	TBD°F
ELECTRICAL	TBD V

ITEM	QTY	DESCRIPTION	MATERIAL	REMARKS
17	1	VORTEX BREAKER (NOT SHOWN)	POLYETHYLENE	
16	4	ANCHOR LUGS (TBD)	ALUMINUM	DT-A-87-026
15	2	VIBRATION SWITCH	STEEL	
14	1	FLOAT VALVE	POLYPROPYLENE	
13	1	LADDER ASSEMBLY (NOT SHOWN)	ALUMINUM	OPTIONAL
12	20	LOUVER PANEL	PVC	
11	1 SET	FILL	PVC	
10	1	STRAINER (NOT SHOWN)	PLASTIC	
9	1	FILL SUPPORT	FRP	
8	1 SET	MIST ELIMINATOR	PVC	
7	1	WATER DISTRIBUTION	PVC	
6	2	VELOCITY RECOVERY STACK	POLYETHYLENE	WITH SCREEN
5	2	PROPPELLER	FRP/POLYPROP	
4	2	ELECTRICAL CONN.	ALUMINUM	
3	2	MOTOR	ALUM./STEEL	TEAO, 900 RPM
2	2	FAN RING	COATED STEEL	
1	1	TOWER SHELL	POLYETHYLENE	

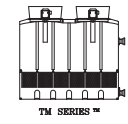

**BILL OF MATERIALS**

**DELTA COOLING TOWERS, INC.**  
 185 US HIGHWAY 206, ROXBURY TWP, NJ, 07836  
 PH (973) 586-2201 FAX (973) 586-2243

TITLE: **1 CELL**

TM SERIES™

JOB #

SCALE 5/8"=1'-0" DWG NO. DT-D-87-901

DATE 6/11/01

DWN BY Bonnie L. Oddo  
 APPVD BY John Flaherty

REV. JH