

TOTAL HP	SEE MODEL
DRY WT.	13,000 LBS.
OPER. WT. SUMP FULL	24,400 LBS.
OPERATING WT. BOTTOM OUTLET	16,900 LBS.
SUMP CAP	960 GALLONS

INFORMATION CONTAINED HEREIN IS SUBJECT TO CHANGE WITHOUT NOTICE IN THE INTEREST OF PRODUCT IMPROVEMENT.

MODEL SERIES	DIM "A"
TM2XX3XX	68"
TM2XX4XX	77 1/2"

IF I-BEAM MOUNTING OPTION IS SELECTED, THE MINIMUM TOP FLANGE WIDTH ON THE I-BEAM IS 8" WIDE

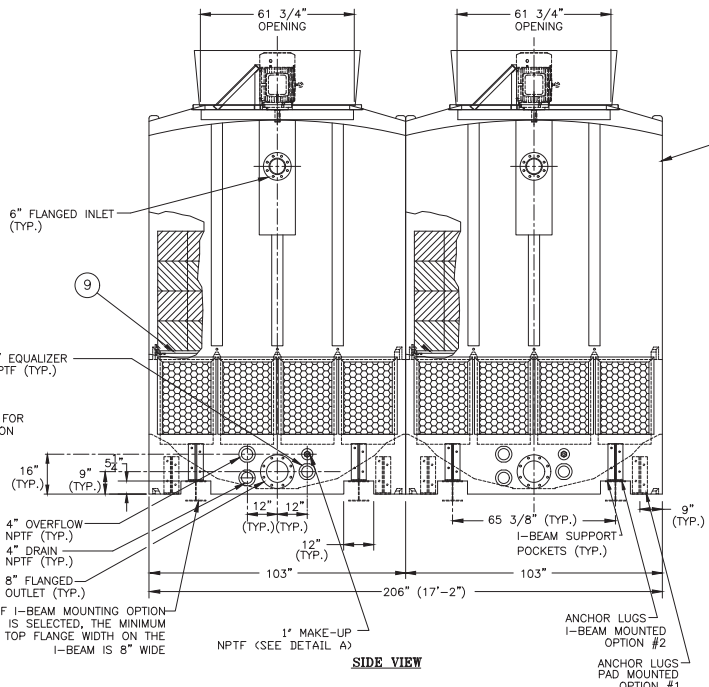
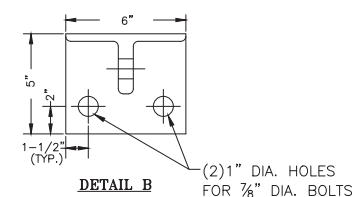
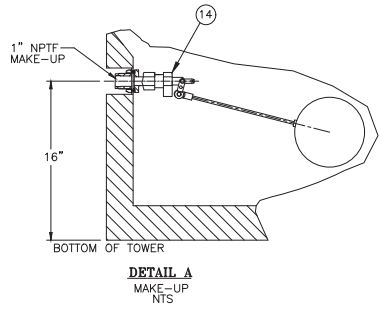

ITEM	QTY	DESCRIPTION	MATERIAL	REMARKS
17	1	VORTEX BREAKER (NOT SHOWN)	POLYETHYLENE	
16	8	ANCHOR LUGS	ALUMINUM	DT-A-87-026
15	4	VIBRATION SWITCH	STEEL	
14	2	FLOAT VALVE	POLYPROPYLENE	
13	1	LADDER ASSEMBLY (NOT SHOWN)	ALUMINUM	OPTIONAL
12	28	LOUVER PANEL	PVC	
11	2 SETS	FILL	PVC	
10	2	STRAINER (NOT SHOWN)	PLASTIC	
9	2	FILL SUPPORT	FRP	
8	2 SETS	MIST ELIMINATOR	PVC	
7	2	WATER DISTRIBUTION	PVC	
6	4	VELOCITY RECOVERY STACK	POLYETHYLENE	WITH SCREEN
5	4	PROPELLER	FRP/POLYPROP	
4	4	ELECTRICAL CONN.	ALUMINUM	
3	4	MOTOR	ALUM./STEEL	TEAO, 900 RPM
2	4	FAN RING	COATED STEEL	
1	2	TOWER SHELL	POLYETHYLENE	

BILL OF MATERIALS

DELTA COOLING TOWERS, INC.
 185 US HIGHWAY 206, ROXBURY TWP. NJ, 07836
 PH 973.586.2201 FAX 973.586.2243

TITLE 2 CELL (3, 5 & 7 1/2 H.P.)

TM SERIES™

SCALE 1/2" = 1'-0" DWG NO. DT-D-87-902V

DATE 6/12/01

DWN BY Bonnie L. Oddo
 APPVD BY John Flaherty

REV.

DATE	SYM	REVISION	AUTH	CHK
2/28/02	A	REV. INLET	BLO	JF
4/8/02	B	REV. OUTLET & POCKETS	BLO	JF
1/28/03	C	ADDED ANCHOR LUG DETAILS	GT	JF
2/4/03	D	ADDED OPTIONAL OUTLET DIM.	GT	JF
5/09/05	E	ADJUST WEIGHTS	JRB	JF
5/09/05	F	ADJUST DIM. W/ ANCHOR LUGS	JRB	JF
8/19/05	G	ADD DIM. ELEVATION TABLE	KF	JF
9/19/06	H	MOD. MAKE-UP ANCHOR LUGS	KF	JBH
2/18/07	I	REVISED NUMBER OF LOUVERS	KF	JBH
1/28/08	J	ADDED SUMP SLOPE NOTE	KF	JBH
2/27/08	K	ADDED VORTEX BREAKER	KF	JBH
9/18/08	L	REVISED BOTTOM OUTLET SQUARE	KF	JBH
4/14/09	M	REVISED HEIGHT	KF	JBH
5/28/10	N	REV. MAKE-UP, LOUVER MATERIAL	KF	JBH
6/10/10	O	REV. MAKE-UP MATERIAL	KF	JBH
4/15/11	P	ADDED FLANGE ADAPTOR NOTE	KF	JBH
10/26/11	Q	ADDED 3HP OPTION	LM	JBH
4/26/13	R	REVISED ANCHOR LUG & BASE DIM	FP	JBH
8/7/14	S	UPDATED DRAWING	FP	JBH
10/9/14	T	I-BEAM POCKET DIMENSION	FP	JBH
8/5/15	U	REVISED MAKE-UP	MO	JBH
2/21/23	V	REV. SIDE OUTLET DIMENSIONS	JBH	JBH

- NOTES:**
- DIMENSIONS SHOWN ARE NOMINAL AND ARE SUBJECT TO FABRICATION TOLERANCES.
 - EXTERNAL PIPING MUST BE INDEPENDENTLY SUPPORTED.
 - PIPING AND BULKHEAD FITTING MATERIAL IS PVC.
 - HARDWARE MATERIAL IS TYPE 304 STAINLESS STEEL.
 - FAN ASSEMBLY SHIPPED INSTALLED ON TOWER.
 - MAXIMUM INLET WATER TEMPERATURE 140°F. (CONSULT FACTORY FOR HIGHER TEMP. APPLICATIONS.)
 - ALL DIMENSIONS ARE IN INCHES.
 - ALL WEIGHTS ARE IN POUNDS. DRY WT. INCLUDES: FAN ASSEMBLY AND TOWER COMPLETE. OPERATING WT. INCLUDES A FULL SUMP.
 - TOWER MOUNTING OPTION #1 - CONCRETE PAD - ENTIRE TOWER BASIN BOTTOM SURFACE TO BE FULLY SUPPORTED BY AN APPROPRIATELY SIZED CONCRETE PAD.
 - TOWER MOUNTING OPTION #2 - BEAM SUPPORTED VIA I-BEAM POCKETS. *SUPPORT BEAMS AND ANCHOR BOLTS ARE TO BE FURNISHED BY OTHERS. *BEAMS SHOULD HAVE A MINIMUM TOP FLANGE WIDTH OF 8"(8"x31# RECOMMENDED) AND BE IN ACCORDANCE WITH ACCEPTABLE STRUCTURAL DESIGN PRACTICES. THESE BEAMS SHOULD BE LOCATED IN THE INTEGRALLY MOLDED I-BEAM POCKETS, AND SHOULD OVER-RUN THE LENGTH OF THE UNIT. *DO NOT WELD OR BOLT DOWN BEAMS PRIOR TO SETTING THE COOLING TOWER SUMP(S).
 - FINAL YARD PIPING TO AND FROM THE TOWER SHOULD BE FABRICATED FOLLOWING INSTALLATION OF THE TOWERS ON-SITE. DUE TO MANUFACTURING AND INSTALLATION TOLERANCES, PREFABRICATION OF EXTERNAL PIPING IS NOT RECOMMENDED.

