

- NOTES:
- DIMENSIONS SHOWN ARE NOMINAL AND ARE SUBJECT TO FABRICATION TOLERANCES.
  - TOWER TO BE INSTALLED ON A FLAT AND RIGID SURFACE, PROPERLY SUPPORTED.
  - EXTERNAL PIPING MUST BE INDEPENDENTLY SUPPORTED.
  - PIPING AND BULKHEAD FITTING MATERIAL IS PVC.
  - HARDWARE MATERIAL IS TYPE 304 STAINLESS STEEL.
  - FAN ASSEMBLY & SPRINKLER ARMS SHIPPED SEPARATELY FOR FIELD INSTALLATION.
  - FOR BOTTOM OUTLET MAXIMUM OPENING IN SUPPORT TO BE 14" X 14". (CONSULT DELTA ENGINEERING FOR LARGER OPENINGS.)
  - MAXIMUM INLET WATER TEMPERATURE 140°F. (CONSULT FACTORY FOR HIGHER TEMP. APPLICATIONS.)
  - ALL DIMENSIONS ARE IN INCHES.
  - ALL WEIGHTS ARE IN POUNDS. DRY WT. INCLUDES FAN ASSEMBLY, SINGLE SPEED MOTOR & TOWER COMPLETE. MAX. FAN WT. INCLUDES FAN ASSEMBLY AND TWO SPEED MOTOR.
  - RISER PIPE HAS 1/4" WEEP HOLE IN SUMP.
  - OPTIONAL H2O HAMMER ARRESTER MAY RELIEVE POTENTIAL WATER HAMMER DUE TO HIGH SUPPLY PRESSURE.
  - SEE DWG. NO DT-D-83-755 FOR MULTICELL LAYOUT.

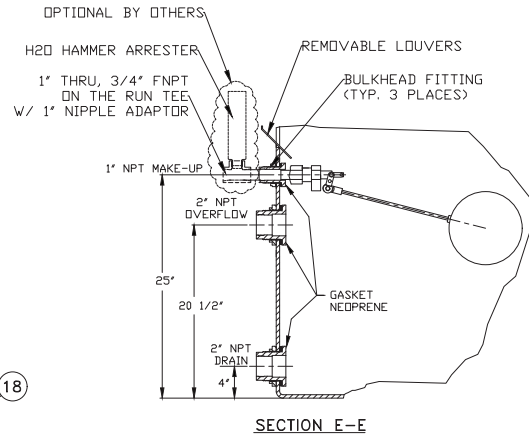
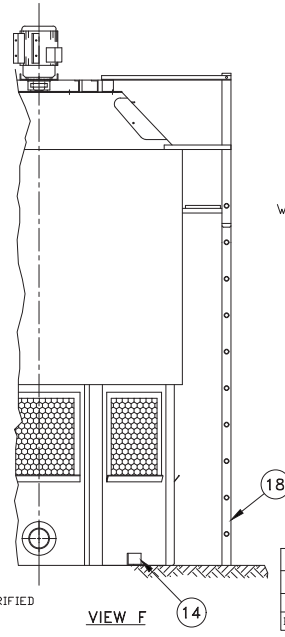
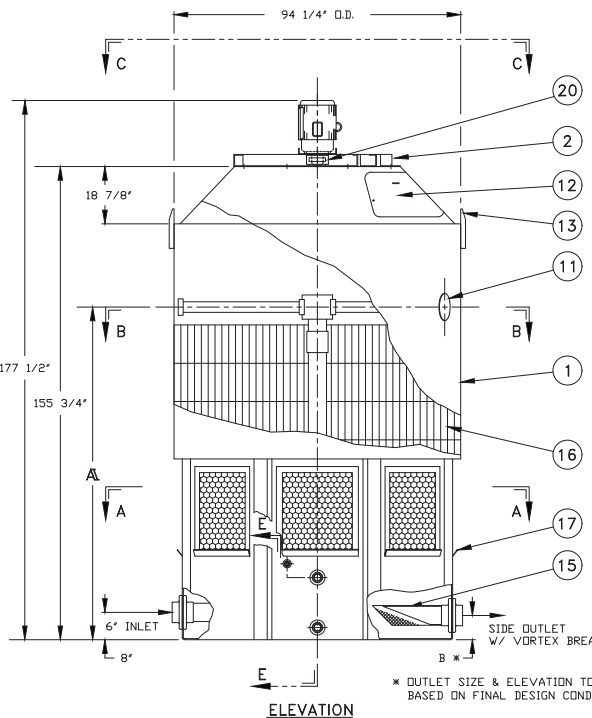

\* 150I TO 175I OUTLET SIZING

OUTLET SIZE	STANDARD 6"	OVERSIZED 8"	MUST BE PUMPED
SIDE OUTLET	325 GPM	550 GPM	>550 GPM
BOTTOM OUTLET	670 GPM	1175 GPM	>1175 GPM

TOWER HP	ΔT 150I	ΔT 175I
7 1/2"	10	10
DRY WT.	1660	1800
OPER. WT.	5570	5810
DESIGN WT.	8325	8570
MAX. FAN WT.	322	485
A	109 1/2"	122 1/2"

ITEM	QTY	PART NO.	DESCRIPTION	MATERIAL	REMARKS
21	1		H2O HAMMER ARREST.	COPPER	OPTIONAL
20	1		VIBRATION SWITCH	STEEL	OPTIONAL
19	1		FLD/AT VALVE	POLYPROPYLENE	
18	1		LADDER ASSEMBLY	ALUMINUM	OPTIONAL
17	1	SET	LOUVER	PVC	
16	1	SET	FILL	PVC	
15	1		STRAINER	PLASTIC	OPTIONAL
14	4		ANCHOR LUG	ALUMINUM	
13	2		LIFTING LUG	ALUMINUM	
12	1		MANHOLE COVER	POLYETHYLENE	
11	1		CLEAN-OUT PRT	POLYETHYLENE	
10	4		MIST ELIMINATOR	POLYETHYLENE	
9	4		PIPE CAP	PVC	
8	4		SPRINKLER PIPE	PVC	
7	1		SPRINKLER HEAD	PVC	
6	1		FAN GUARD	COATED STEEL	
5	1		PROPELLER	POLYPROP/FRP	
4	1		ELECTRICAL BOX	ALUM.	
3	1		MOTOR	ALUM./STL.	
2	1		FAN RING	COATED STEEL	
1	1		TOWER SHELL	POLYETHYLENE	

**BILL OF MATERIALS**

**DELTA COOLING TOWERS, INC.**  
 185 US HIGHWAY 206 ROXBURY TOWNSHIP NJ 07836  
 PH 973.586.2201 FAX 973.586.2243

**TITLE** ΔT 150I AND ΔT 175I

**PARAGON SERIES** DWN BY Alexander Elements  
 JOB # APPVD BY W.A. Puller

**SCALE** 5/8"=1'-0" **DWG NO.** DT-D-83-754 **REV.** N

**DATE** 9/20/96

NOT TO BE USED FOR FABRICATION

INFORMATION HEREIN IS SUBJECT TO CHANGE WITHOUT NOTICE IN THE INTEREST OF PRODUCT IMPROVEMENT.

OUTLET SIZE TO BE VERIFIED BASED ON FINAL DESIGN CONDITIONS.

DATE	BY	REVISION	AUTH/CHK
9/20/96	A	DRAWN IN CAD	ACK/PFP
7/23/98	B	REV. FAN RING & DIM.	BDJ/P
12/12/00	C	ADDED NOTE 12	BDJ/P
6/21/01	D	REV. BOT. OUTLET SIZE	BDJ/P
5/23/05	E	REV. FAN ASSEMBLY	BDJ/P
10/25/07	F	REVISED ELIMINATOR BLADES	KF/DB
11/14/08	G	REVISED MANWAY SIZE	KF/DB
6/1/10	H	REVISED MAKE-UP	KF/DB
6/10/10	I	REVISED MAKE-UP MATERIAL	KF/DB
12/16/10	J	REVISED OUTLET HEIGHT	KF/DB
6/2/11	K	OPT. H2O HAMMER ARRESTER	LM/DB
7/30/15	L	REV. MAKE-UP ASSEMBLY	MJ/DB
2/9/18	M	ADDED OUTLET SIZING NOTE	SS/PFP
4/1/25	N	STANDARD LADDER ORIENTATION	SS/PFP